



SERVICE BULLETIN No. 300 for members of RADIO MANUFACTURERS SERVICE

A PHILCO Service Plan

SPECIFICATIONS

TYPE OF CIRCUIT: A. C. operated; superheterodyne circuit, covering standard broadcast band (540 K. C. to 1720 K. C.); Automatic Volume Control; and pentode output.

Codes 121 and 122 chassis of this model are similar with the exception of Speaker and Cabinet.

The receiver is designed to operate from a "Philco Utility Aerial," part No. 45-2450. This aerial system should be used to obtain maximum performance from the receiver.

POWER SUPPLY: Voltage—115 volts. Frequency—50-60 cycles. Power consumption—40 watts.

INTERMEDIATE FREQUENCY: 470 K. C.

TUNING RANGE: 540 to 1720 K. C.

AUDIO OUTPUT: 2 watts.

PHILCO TUBES USED: Five tubes: 1-6A7, 1st detector and oscillator; 1-78, I. F.; 1-75, 2nd detector, Automatic Volume Control, and 1st audio; 1-41, Output; and 1-84, Rectifier.

TUNING MECHANISM: Pulley and cable drive for Manual tuning. Push-Button for Automatic Tuning. The procedure for adjusting and operating the Automatic Tuning Push-Buttons will be found in the instructions supplied with each set.

CABINETS: Code 121 chassis in type "T" cabinet. Code 122 chassis in type "F" cabinet.

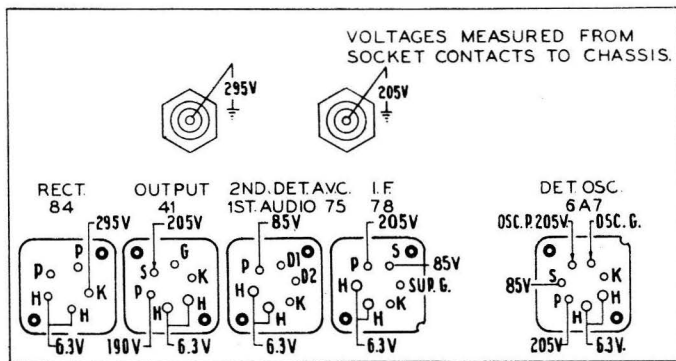

Fig. 1. Socket Voltage—Underside of Chassis View

The voltages indicated by arrows were measured with a Philco 027 Circuit Tester, which contains a sensitive voltmeter. Volume Control at minimum—Tuning Condenser set for no signal—line voltage 115 A. C.

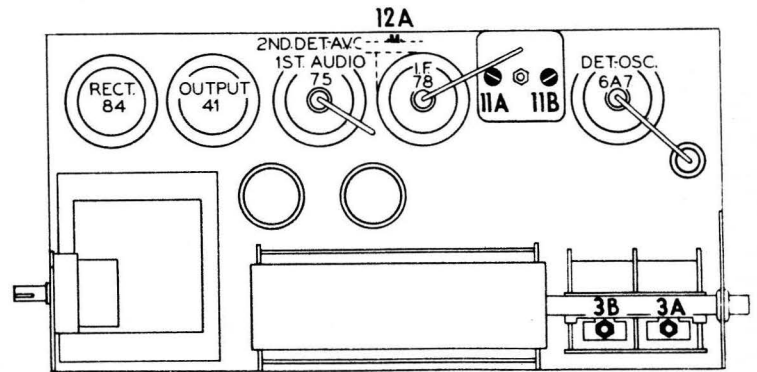

Fig. 2. Locations of Compensators

Alignment of Compensators

EQUIPMENT REQUIRED: (1) Signal Generator: Philco Model 077 Signal Generator which has a fundamental frequency range from 115 to 36,000 K. C. is the correct instrument for this purpose. (2) Output meter, Philco Model 027 Circuit Tester, incorporates a sensitive output meter and is recom-

mended (3) Philco Fiber Handle Screw Driver, part No. 27-7059, and Fiber Wrench, part No. 3164

OUTPUT METER: The Philco 027 Output Meter is connected to the plate and cathode terminals of the type 41 tube. Set the meter to use the 0-30 volt scale.

Operations In Order	Signal Generator			Receiver			Special Instructions
	Output Connections To Receiver	Dummy Antenna (Note A)	Dial Setting	Dial Setting	Control Settings	Adjust Compensators In Order	
1	6A7 Grid	.1 mf.	470 K. C.	580 K. C.	Vol. Cont. (Max.)	(12A) (11A) (11B)	
2	Ant. Ter.	100 mmf.	1550 K. C.	1550 K. C.	Vol. Cont. (Max.)	(3B) (3A)	See Note B

NOTE A—The "Dummy Antenna" consists of a condenser connected in series with the signal generator output lead (high side). Use the capacity as specified in each step of the above procedure.

NOTE B—**DIAL CALIBRATION:** In order to adjust the receiver correctly, the dial must be aligned to track properly with

the tuning condenser. To adjust the dial proceed as follows: With the push button unit disconnected from the gang, the pointer is to be set on the extreme left edge of the index line (low frequency end of the scale) with the gang closed. The gang is then opened until the pointer is at the right edge of the index line and, with the push button shaft at its closed stop, the push button coupling is tightened on the gang shaft.

REPLACEMENT PARTS Model 39-17; Codes 121 & 122

Schem. No.	Description	Part No.
1	Antenna Transformer	32-3039
2	Condenser (.05 mf. tubular)	30-4519
3	Tuning Condenser Assembly	31-2265
4	Resistor (51,000 ohms, 1/2 watt)	33-351339
5	Condenser (110 mmf. mica)	30-1031
6	Condenser (25 mmf., silver plated mica)	30-1112
7	Oscillator Transformer	32-3040
8	Resistor (3.0 megohm)	33-530339
9	Condenser (.03 mf. tubular)	30-4449
10	Resistor (40,000 ohms, 1/2 watt)	33-340339
11	1st I. F. Transformer Assembly	32-3075
12	2nd I. F. Transformer Assembly	32-2944
13	Resistor (51,000 ohms, 1/2 watt)	33-351339
14	Volume Control and On-Off Switch	33-5276
15	Condenser (.01 mf. tubular)	30-4479
16	Condenser (mica), 250 mmf.	30-1032
17	Condenser (.01 mf. tubular)	30-4572
18	Resistor (16,000 ohms, 1/2 watt)	33-316339
19	Resistor (1.0 megohm, 1/2 watt)	33-510339
20	Resistor (4.0 megohm, 1/2 watt)	33-540339
21	Condenser (.01 mf. tubular)	30-4572
22	Output Transformer	32-7980
23	Cone and Voice Coil Assembly for Speaker (Part No. 36-1426-1)..... (Part No. 36-1426-3)..... Cone and Voice Coil Assembly for Speaker (Part No. 36-1440).....	36-4083 36-4085 36-4086
24	Resistor (250 ohms, wire wound)	33-125431
25	Resistor (70 ohms, 1/2 watt)	33-070339
26	†Field Coil for Speaker (Pt. No. 36-1426) †Field Coil for Speaker (Pt. No. 36-1440)	
27	Condenser (12 mf. electrolytic)	30-2319
28	Condenser (4 mf. electrolytic)	30-2236
29	Condenser (.03 mf. tubular)	30-4449
30	Power Transformer (115 volts, 50-60 cycles)	32-7974
31	Condenser (.01 mf., bakelite)	3903DG
32	Pilot Lamp	34-2064
33	Pilot Lamp	34-2064

MISCELLANEOUS PARTS

Description	Part No.
Automatic Tuning Unit (complete)	31-2282
Bezel Assembly (dial)	40-6364
Bezel Gasket (dial)	27-9174
Bezel (push buttons)	28-5929
Bezel Gasket (push buttons)	27-9218
Bezel Clamp (dial)	28-5153
Cable and Plug (power)	L-2778
Dial and Frame Assembly	31-2283
Dial Tuning Drum Assembly	31-2281
Dial Tuning Cord Assembly	31-2275
Dial Tuning Spring (cord)	28-8919
Clip (Mtg. R. F. Coils)	28-5002
Clip (Mtg. R. F. Coils)	28-5003
Escutcheon Plate (extension shafts, F cabinet)	56-1051
Escutcheon Pin	W-950
Knob (Tuning)	27-4750
Knob (Volume)	27-4753

Pilot Lamp Socket Assembly	38-9612
Pointer (dial)	28-5934
Push-Buttons	27-4749
Shaft Extension (Volume)	38-9640
Shaft Extension (Tuning)	28-6928
Sleeve-long Tuning Shaft Extension (F Cabinet)	28-6935
Sleeve-short Tuning Shaft (T and F Cabinet)	28-6887
Spring-retaining Volume Shaft	28-8915
Socket (6 prong)	27-6036
Socket (7 prong)	27-6107
Socket (5 prong)	27-6035
Speaker (F Cabinet)	36-1440
*Speaker (T Cabinet)	

Tab Kit optional { 36-1426-1
36-1426-3
40-6391

* When ordering Speaker or Cone assembly specify which of the small numbers (-1 or -3) following the part number is required.

† Replace Speaker.

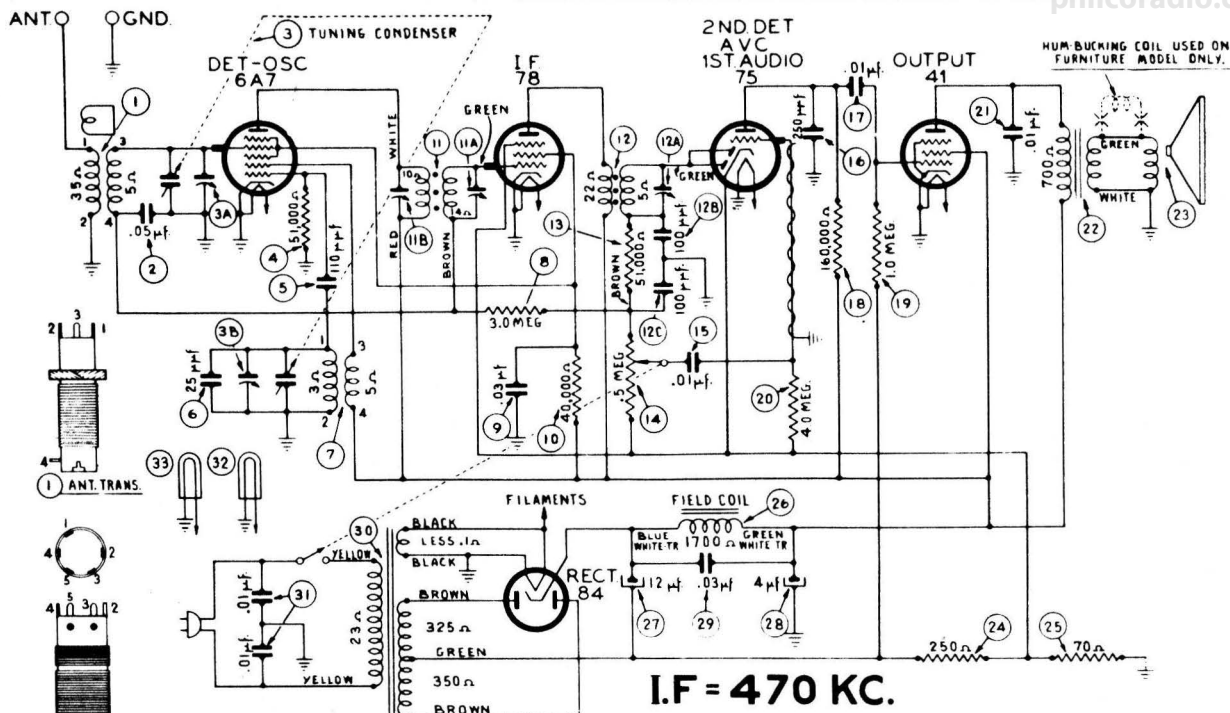

Fig. 3. Schematic Diagram—Model 39-17, Code 121-122

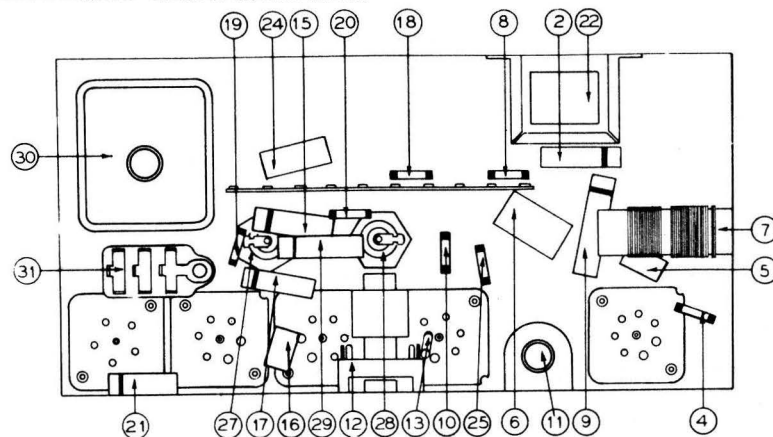

Fig. 4. Part Locations, Underside of Chassis

PHILCO RADIO AND TELEVISION CORPORATION
Parts and Service Division
Philadelphia, Pa.